

**Robust Modular Design
with High Flexibility**



Motor Control Centre

ENCLOSURES



Our Product Range

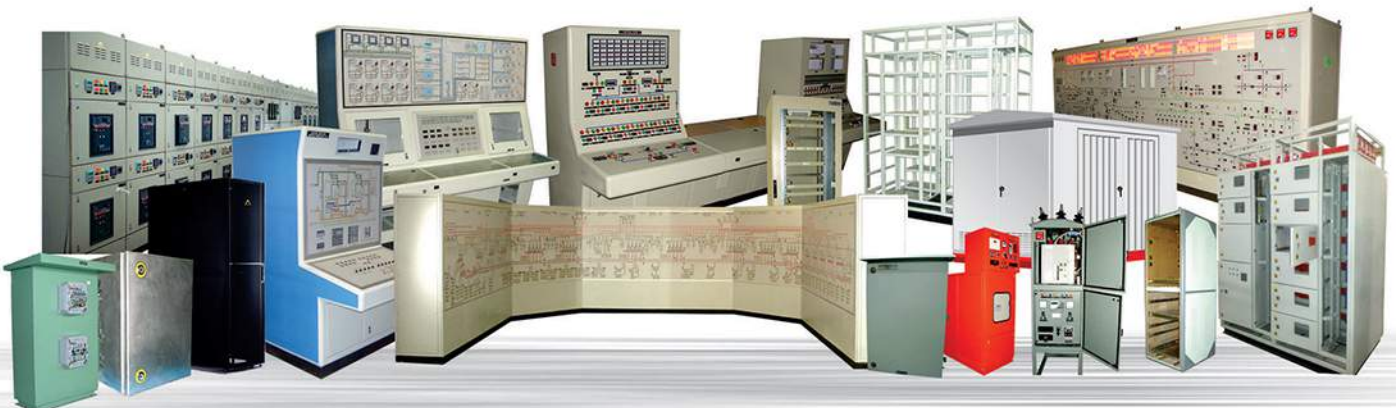

- Shelter • Mosaic Desk • Console Desk • Bare Panel IP-65 • PLC Panel •
- Mosaic Minic Panel • Local Control Station • FRP Box • LIE - LIR • Power Distribution Box •
- Purge & Ex-proof • Acrylic Mimic • NG / LAVT Cubicle • Generator Control Panel •
- MCC / PCC / IMCC • CT Box • APFC Panel • Bus Duct (NSPD) • Soft Starter Panel •
- Synchronization Panel • HT Panel • Large Video Screen • Networking Panel •
- Bare Panel IP-55 • Junction Box • Control & Relay Panels • Alcosy Control Desk •
- Metering Panel • Metering Box • Marshalling Panels • EMI/RFI Compliant Panel •
- Universal Test Bench • Push Button Station • 19" Racks • Control Room Interiors •

Why **Pyrotech**?

INFRASTRUCTURE

- World class state of art panel building infrastructure / Facility
- Design engineering under one roof CNC, Fabrication, Powder Coating, Assembly, Wiring & Testing.
- In house Testing Laboratory & Temperature rise testing setup.

CAPABILITY

- Single source for all types of IT panels / DBS-wired & bare.
- Fixed type, Drawout type & intelligent MCCs.
- Providing customized & standard products & solutions.
- IEC & IS Standard Compliance

CREDENTIALS

- ERDA approved type test approvals for Panels & Bus Ducts covering
 - (i) Short Circuit Test
 - (ii) Temperature Rise Test
 - (iii) Enclosure Protection Class Test
- Approved vendor of Central & State Governments, Public and Private sectors
- Established Brand for last 37 years.

Motor **Control** Centre (MCC) Cubicle

Pyrotech **Construction** Type :

- 1. Welded**
- 2. Semi-welded (Bolted)**

We are recognized as one of the leading manufacturers of (Motor Control Center) MCC panels widely appreciated across the country. These are designed to satisfy the to-days industrial demands to meet varied technical requirements & to suit varying site conditions. The design confirms to latest national and international standards.

Our MCC & PCC are made in modular cabinet system, designed for powering and controlling motors. These are built in accordance with the latest IS 8623 – 1977 and IEC439 standards, utilizing new manufacturing techniques and machines to ensure consistent quality.



Main **Frame** (Welded Panel)

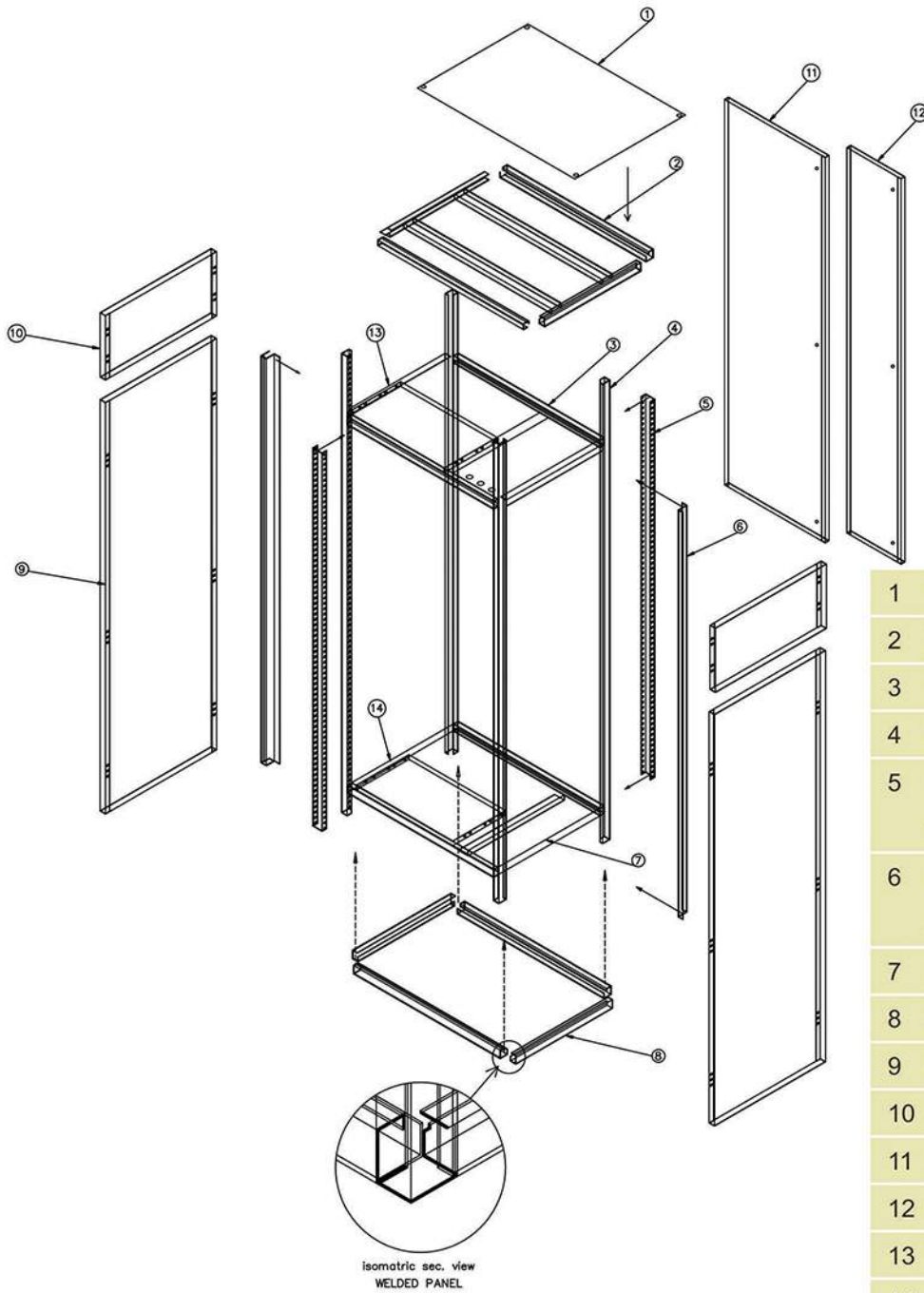

- 1 Top Sheet
- 2 Top Frame
- 3 Top Middle Channel
- 4 Main Vertical Channel
- 5 Front & Rear MID Vertical Channel
- 6 LHS & RHS Fixing Section
- 7 Bottom Middle Channel
- 8 Bottom Frame
- 9 Side Cover Bottom
- 10 Side Cover Top
- 11 Rear Cover
- 12 Cable Alley Cover
- 13 Top Middle Partition Cover
- 14 Bottom Middle Partition Cover



PU Gasket (Jointless)



IP Lock Arrangement



Earthing Kit



Sectional View

Main **Frame** (Bolted Panel)

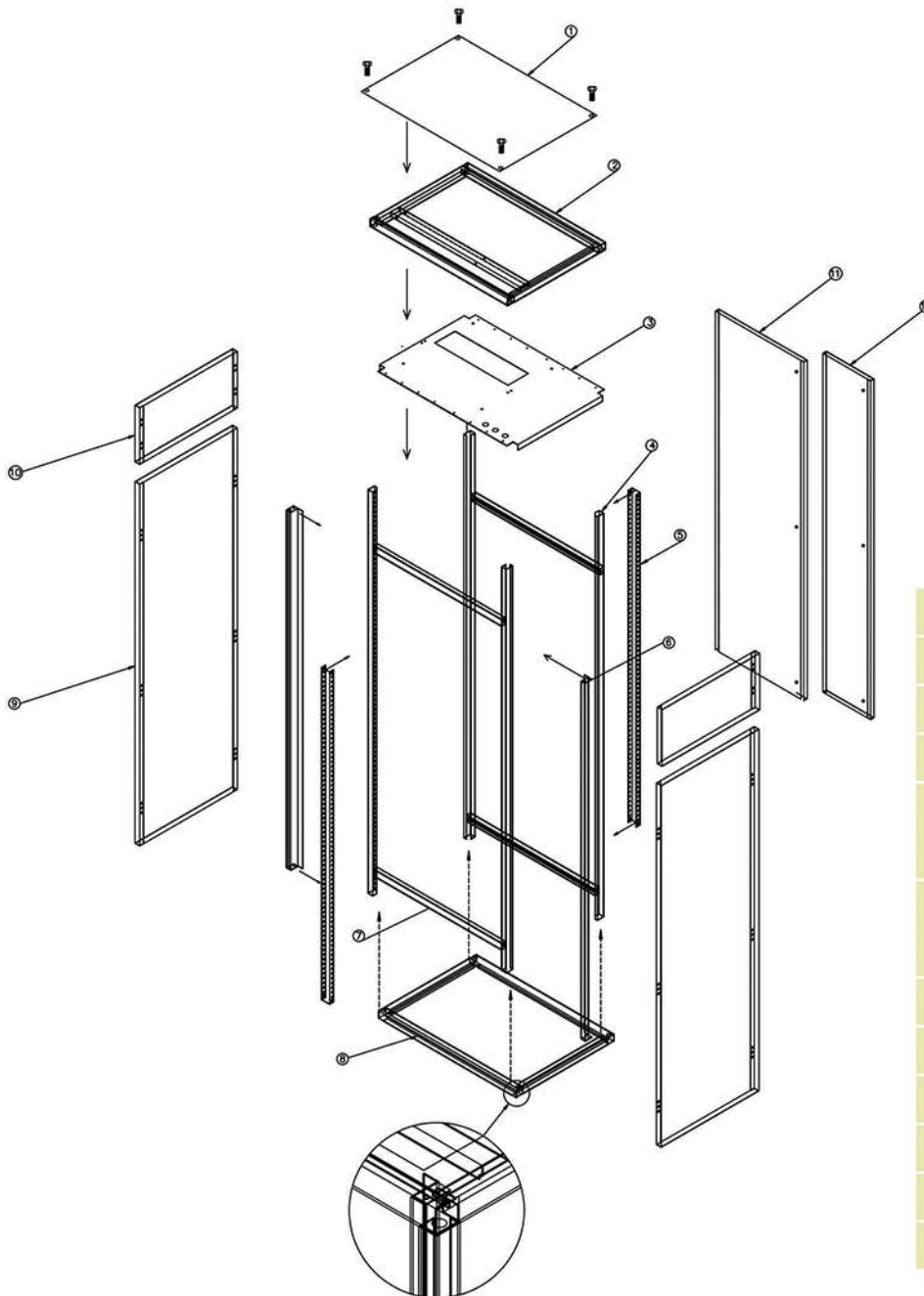

isometric sec. view
BOLTED PANEL

- | | |
|----|-----------------------------------|
| 1 | Top Sheet |
| 2 | Top Frame |
| 3 | Middle Top Sheet |
| 4 | Main Vertical Frame |
| 5 | Front & Rear MID Vertical Channel |
| 6 | LHS & RHS Fixing Section |
| 7 | Bottom Middle Channel |
| 8 | Bottom Frame |
| 9 | Side Cover Bottom |
| 10 | Side Cover Top |
| 11 | Rear Cover |
| 12 | Cable Alley Cover |

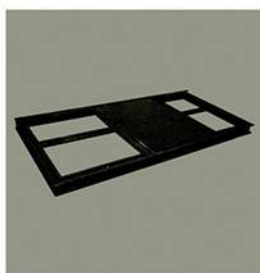

Base Frame



Hinge



Front View



Door Arrangement

Our Panels :



Type of MCC & PCC Cubicles Manufactured by us

1. **Fixed Type MCC** : A. Single Front Construction, B. Double Front Construction
2. **Drawout Type MCC** : A. Single Front Construction, B. Double Front Construction

FIXED TYPE MCC ENCLOSURE

Salient features:

- Fully compartmentalized modular design
- As per Standards IS 8623 & IEC 60439
- Unique Techno Modular construction with CRCA sheet steel
- Form 3b for standard MCC Construction.
- Form 4b for optional cases.
- Totally enclosed vermin and dustproof.
- Main bus bar HBB is approachable from the top.
- Spacious horizontal bus bar chamber for better heat dissipation.
- Modular construction with wide choice of compartment size.
- Standard Compartment size minimum 200 mm and up to 1800mm height in step of 25mm.
- The main and dropper bus sections braced to withstand a fault current of 50kA / 65kA.**
- Horizontal Busbar & Back cover for Bus bars is provided with bolted covers.
- Bolted design and assembly allow ease of alteration or extension at both side.
- Large cabling space with adequate cable supports, are provided in Cable Alley.
- Doors are open able with hinges for 110° opening.
- PU Foam Gasket – joint less, Temperature withstands capability -40° to +120°C.
- Sheet metal Processed by hot 9 Tank pre-treatments.
- Powder Coating with RAL 7035 / RAL 7032 or user specified structure finish for enclosures
- HBB and VBB are Aluminium E91E Grade or Electrolytic grade copper bus bars with PVC colour coating sleeve.
- Short Circuit withstands capability tested at ERDA bus bar system suitable for 50 KA for 1 sec. & 105KA Peak.
- Available in IP 52, 54 & IP: 55

Test Certificate Available :

IP : 53 / 54 / 55

Upto 4000A, 50 kA for 1 sec (Short CKT Test)

Temperature Rise Test 4000A

** Optional



Constructional Features :

Single Front Fixed Type MCC

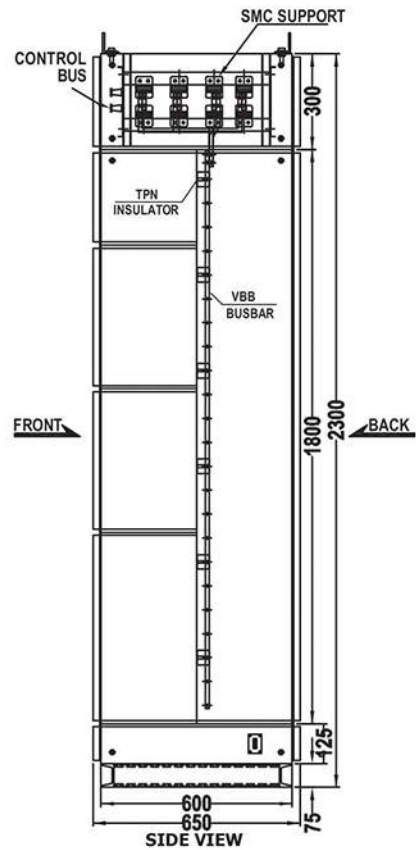
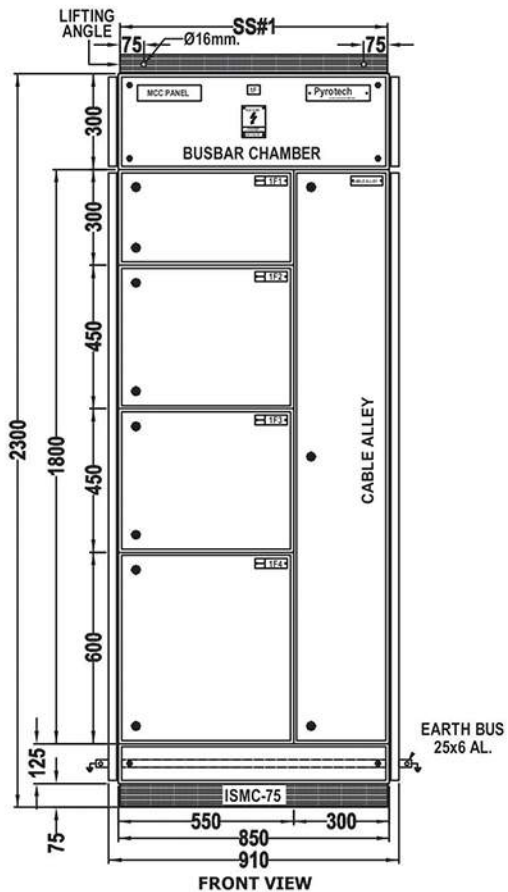
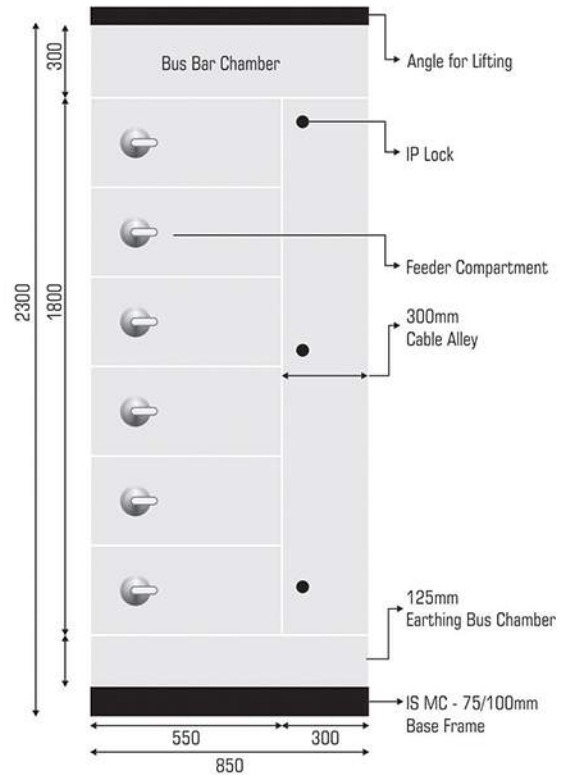

Double Front Fixed Type MCC

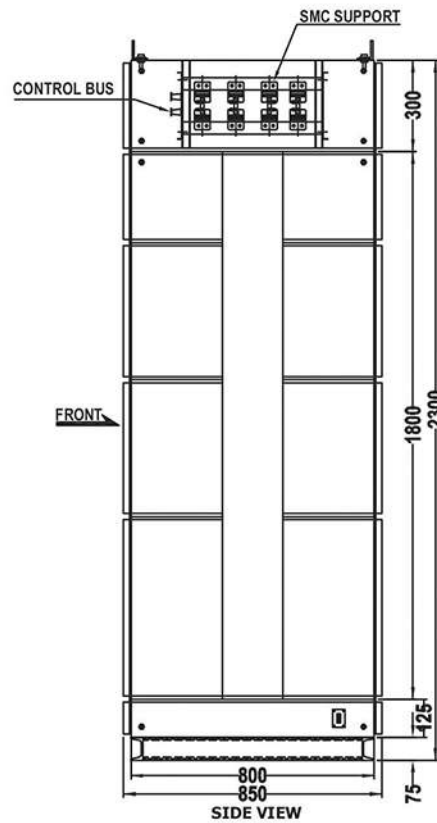
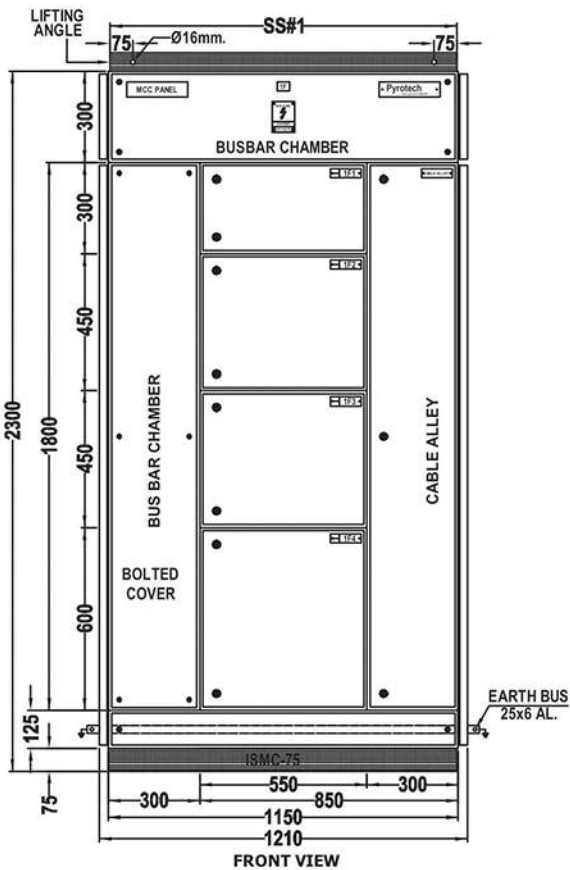
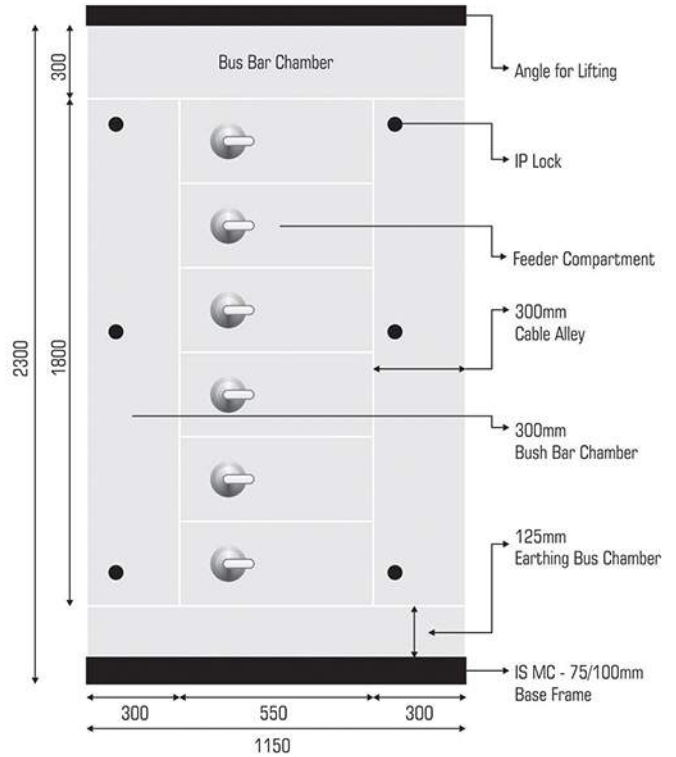

Standard Fixed MCC Enclosure

Test Certificate Available :

IP 54

IP 55

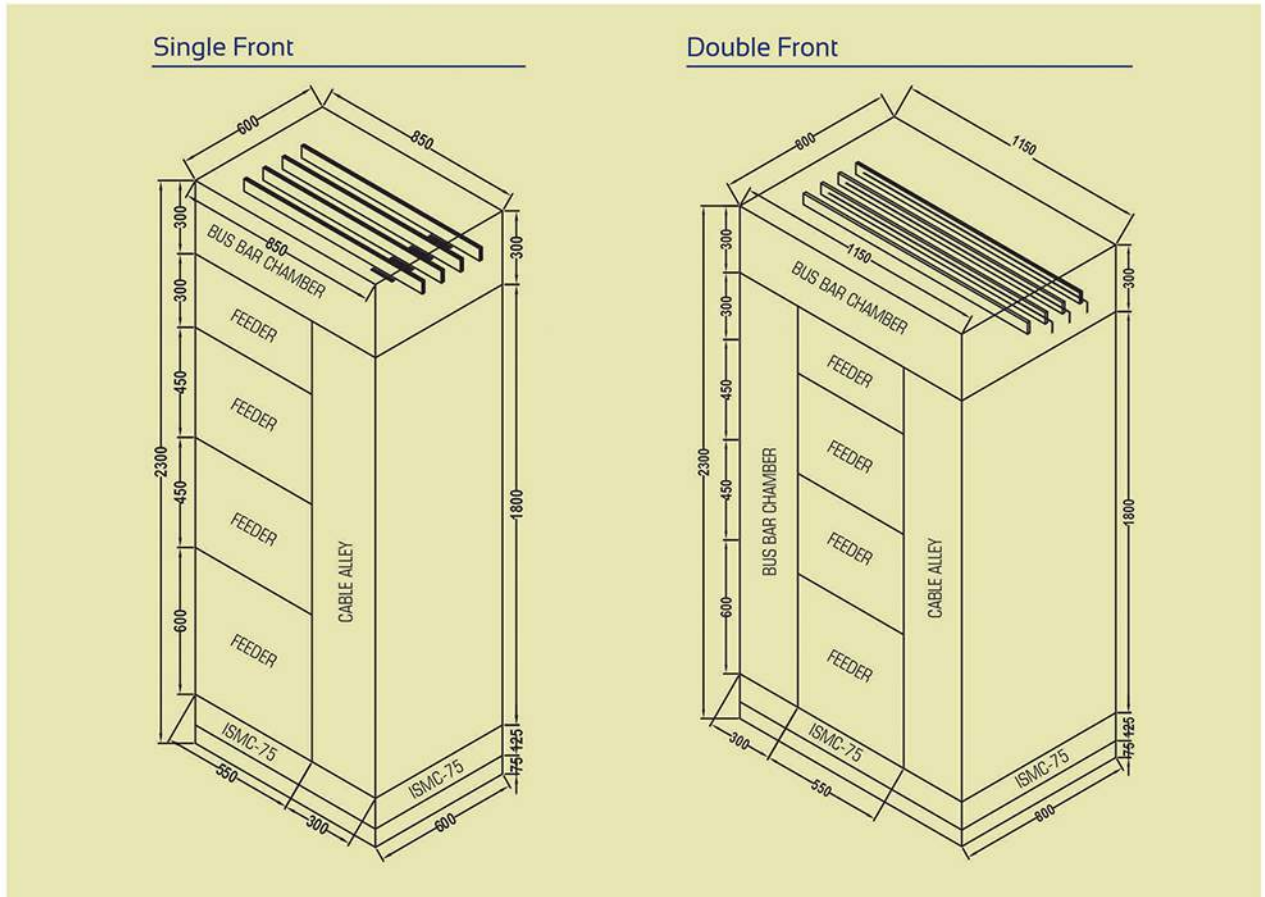

Standard Enclosure Dimensions for Conventional MCC

Parameters	Single Front	Double Front
Height (Over-all)	2300mm / 2400mm	2300mm / 2400mm
Width (feeder + cable alley)	850mm (550 +300) mm	1150mm (550 +300+300) mm
Depth	450 / 600mm	800mm
Standard Compartments Size Options	200 / 225 / 300 / 450 / 600 / 750 / 900 / 1200	225 / 300 / 450 / 600 / 750 / 900 / 1200
Busbar Chamber Height	300mm / 400mm	300mm / 400mm
Cable Alley (Height x Width)	1800 x 300 mm	1800 x 300 mm
ISMC Base channel	75 / 100mm	75 / 100mm
Lifting	Lifting Angle / Eye Bolt	Lifting Angle / Eye Bolt
Locking	IP Lock with Pad Locking	IP Lock with Pad Locking
Construction Type	3b / 4b (Optional)	3b / 4b (Optional)
Frames in Gauge / mm		
Structure & load bearing members	14-gauge / 2mm	14-gauge / 2mm
Doors	16-gauge / 1.6mm	16-gauge / 1.6mm
Partitions	16-gauge / 1.6mm	16-gauge / 1.6mm
Mountain Plate	10-gauge / 3mm	10-gauge / 3mm
C G Plate	10-gauge / 3mm	10-gauge / 3mm

DRAWOUT TYPE MCC ENCLOSURE

Salient features:

- Fully compartmentalized design.
- As per Standards IS 8623 & IEC 60439
- Unique Techno Modular construction with CRCA sheet steel
- Suitable for all make of switchgears.
- Draw out trolleys/module incoming and outgoing power and control contacts automatically also late without manual disengagement in three distinct position i.e. service, test, isolate.
- All Draw out units are fully interchangeable.
- Totally enclosed vermin and dust proof.
- Safety shutters provided accidental contact from vertical bus bars.
- Latest design of our draw out enclosure provides maintenance free vertical bus bars without joint.
- Main bus bar HBB is approachable from the top.
- Self aligning and disconnecting power and control contact.
- Racking Screw arrangement with telescopic rails system provide safe and sure. Smooth movement like Draw out and insertion module.
- New design provide top and bottom guide along with swiveling lever for easy module withdrawal without tools.
- Modular construction with wide choice of compartment size.
- Standard Trolley Size 300, 450, 600, 750, 900.
- The main and dropper bus sections braced to withstand a fault current of 50kA / 65kA.**
- Bolted design and assembly allow ease of alteration or extension at both side.
- Hinged auxiliary door inside main compartment door permit mounting of control accessories, such as meters, selector switch, indicating lamps, push buttons and reset actuator.
- Further this system improves better utilization of equipment plate and total interchangeability of trolleys.
- Spring loaded scraping earthing provided with first make and last brake arrangement.
- Large cabling space with adequate cable supports, are provided in cable alley.
- Rating of plug in contacts varies from 63A, 100A , 125A , 160A , 250A , 400A and 630A
- PU Foam Gasket – Temperature withstand capability -40° to +120°C.
- Sheet metal treatment by 7 Tank process.
- Powder Coating with RAL 7035 / RAL 7032 or user specified structure finish for enclosures
- HBB and VBB are Aluminium E91E Grade or Electrolytic grade copper bus bars with PVC colour coating sleeve.
- Short Circuit withstands capability tested at ERDA bus bar system suitable for 50 KA for 1 sec. & 105KA Peak.

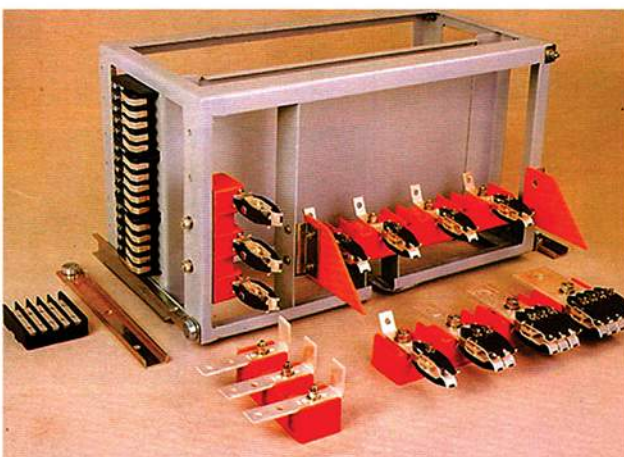

Test Certificate Available :

IP : 53 / 54 / 55

50 kA for 1 sec (Short CKT Test)

Temperature Rise Test

** Optional



Constructional Features :

Single Front Drawout Type MCC

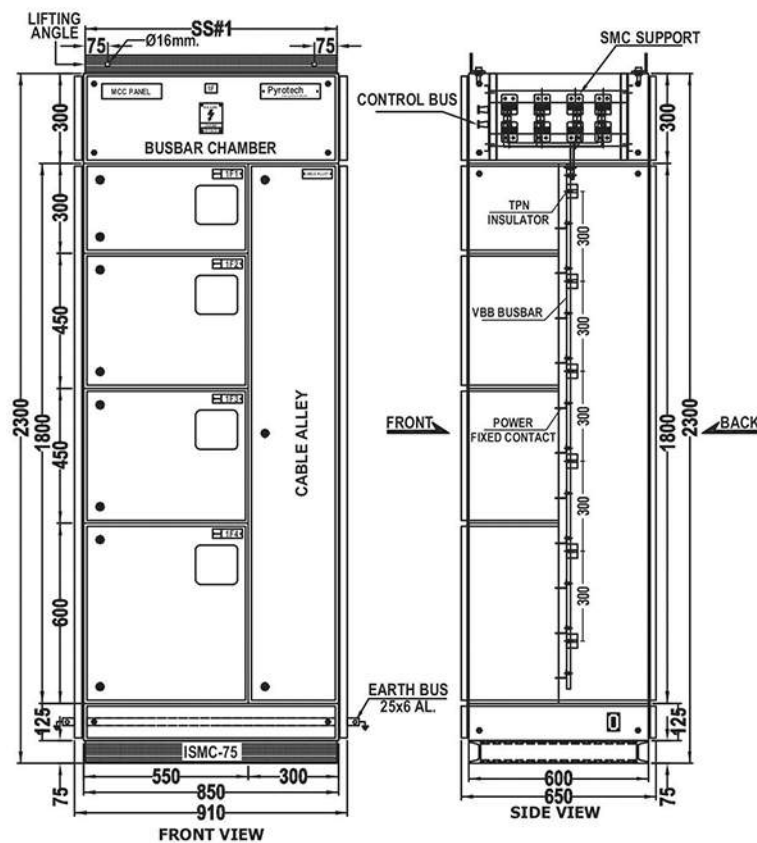

Standard Drawout MCC Enclosure

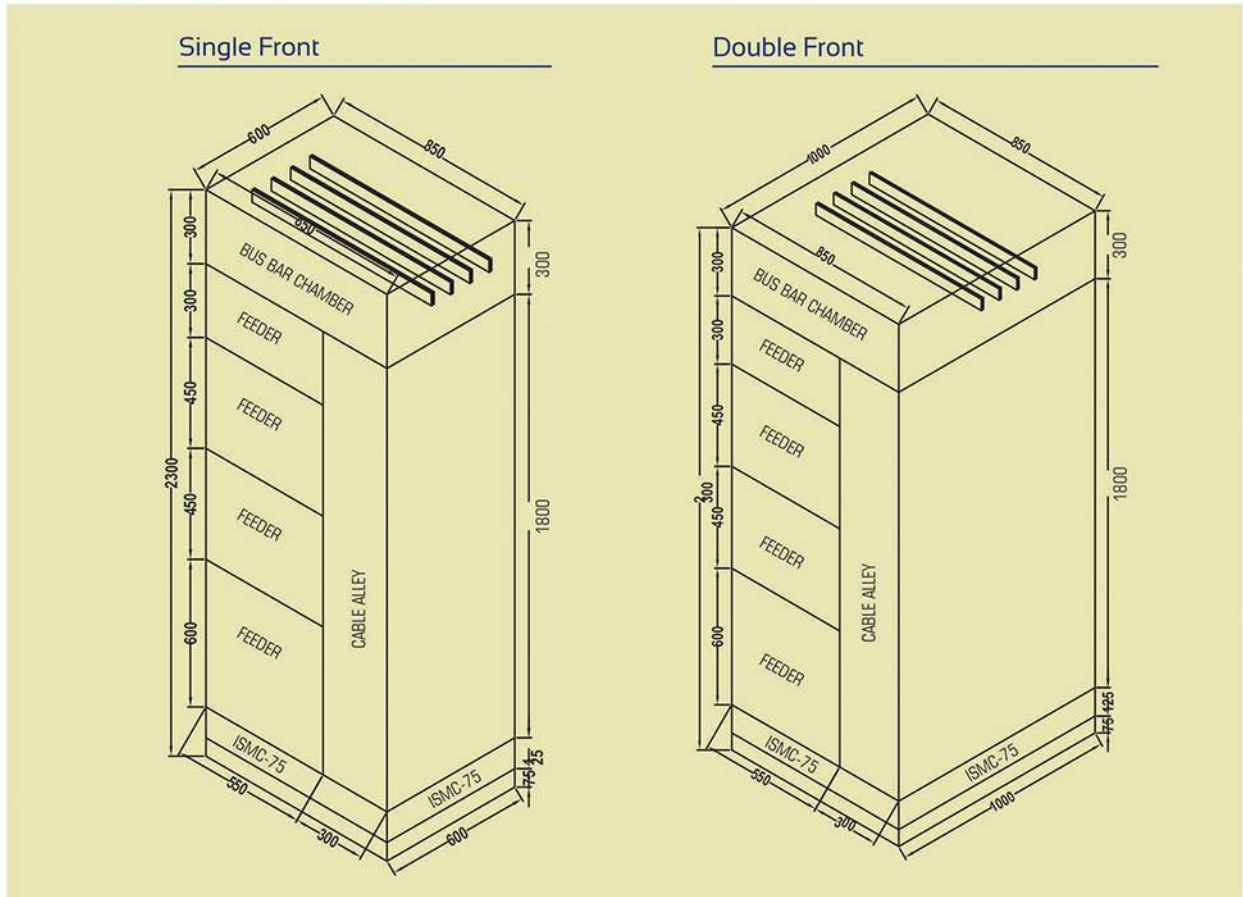

Standard Enclosure Dimensions for Drawout MCC

Parameters	Single Front	Double Front
Height (Over-all)	2300mm / 2400mm	2300mm / 2400mm
Width (feeder + cable alley)	850mm (550 +300) mm	850mm (550 +300) mm
Depth	600mm	1000mm
Trolley Size Standard	300 / 450 / 600 / 750 / 900	300 / 450 / 750 / 900
Busbar Chamber Height	300mm / 400mm	300mm / 400mm
Cable Alley (Height x Width)	1800 x 300 mm	1800 x 300 mm
ISMC Base channel	75 / 100mm	75 / 100mm
Lifting	Lifting Angle / Eye Bolt	Lifting Angle / Eye Bolt
Locking	IP Lock	IP Lock
Construction Type	3b / 4b (Optional)	3b / 4b (Optional)
Frames in Gauge / mm		
Structure & load bearing members	14-gauge / 2mm	14-gauge / 2mm
Doors	16-gauge / 1.6mm	16-gauge / 1.6mm
Partitions	16-gauge / 1.6mm	16-gauge / 1.6mm
Mounting Plate	10-gauge / 3mm	10-gauge / 3mm
C G Plate	10-gauge / 3mm	10-gauge / 3mm

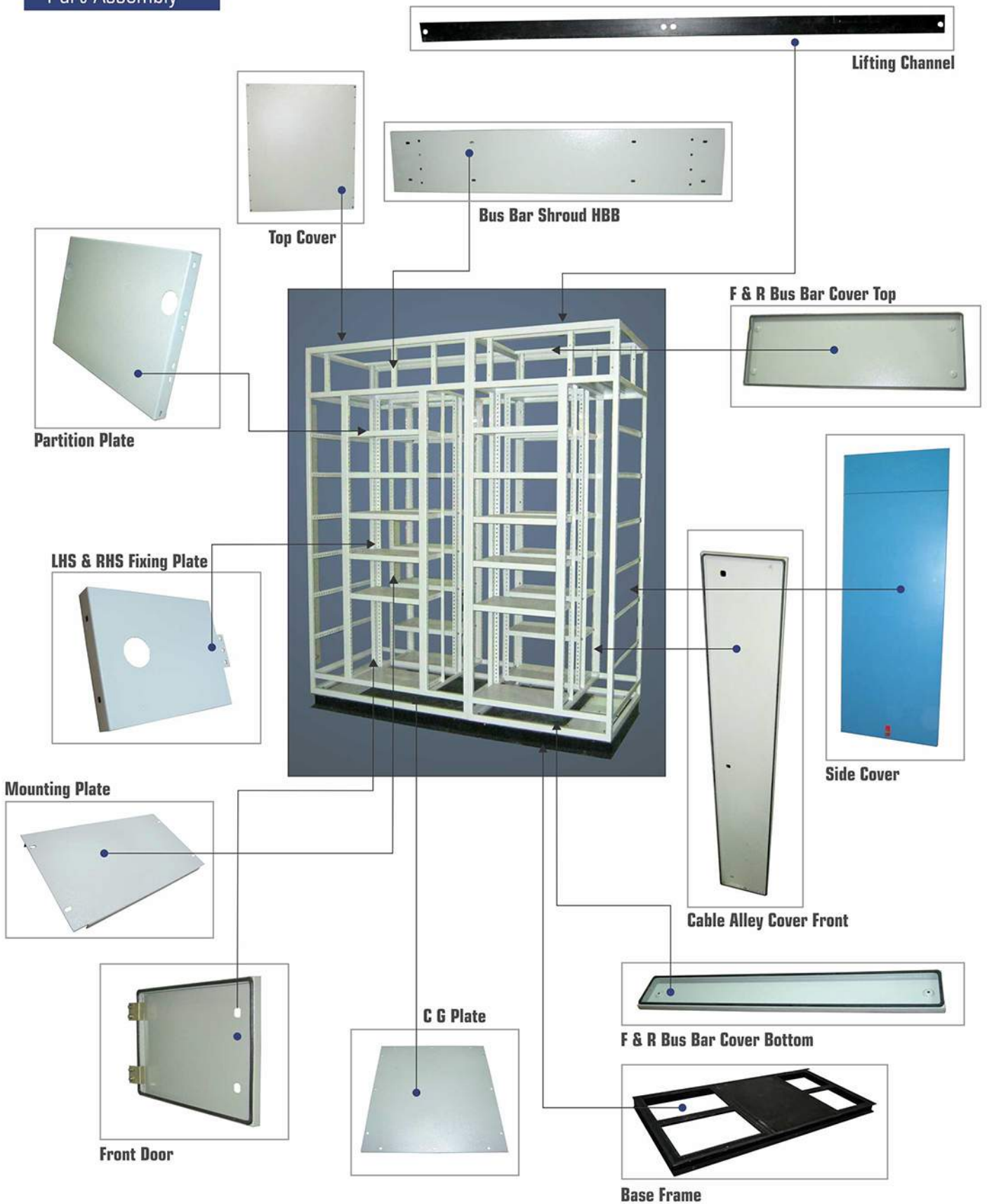
Part Assembly

MCC ENCLOSURE PARTS DETAIL

MCC PARTS DETAIL		WELDED				
COMPARTMENT	DESCRIPTION	FIXED TYPE				
		SINGLE FRONT		DOUBLE FRONT		
		Qty.	Order No.	Qty.	Order No.	
 <p style="text-align: center;">Main Vertical Structure</p>	Base Frame ISMC	1	MEI001	1	ME2001	
	C G Plate	2	MEI002	4	ME2002	
	C G Plate Support	1	MEI003	3	ME2003	
	Main Vertical Channel	4	MEI004	4	ME2004	
	LHS/RHS Top Channel (Depth)	2	MEI005	2	ME2005	
	Bottom Channel (Depth)	2	MEI006	2	ME2006	
	Front / Rear Top Channel (Width)	2	MEI007	2	ME2007	
	Bottom Channel (Width)	2	MEI008	2	ME2008	
	RHS Rear Tray Fixing Section	1	MEI009	2	ME2009	
	LHS Rear Tray Fixing Section	1	MEI010	2	ME2010	
	Front & Rear Mid Vertical Channel	2	MEI011	2	ME2011	
	Section for Front Height (Bus Bar Comp.)	6	MEI012	6	ME2012	
	Top / Bottom Middle Channel Depth Side	4	MEI013	4	ME2013	
	Top / Bottom Cross Angle (Support)	2	MEI014	2	ME2014	
	Top / Bottom Middle F/R Channel (Width)	4	MEI015	4	ME2015	
	Cable Fixing Angle	6	MEI016	12	ME2016	
	Top Plate Supporting Channel (Width)	2	MEI017	2	ME2017	
	HBB Fixing Channel (Single / Double)	4	MEI018	4	ME2018	
	 <p style="text-align: center;">Covers</p>	RHS / LHS Side Cover (Bottom)	2	MEI019	2	ME2019
		RHS / LHS Side Cover (Top)	2	MEI020	2	ME2020
Front & Rear Cover (Bus Bar Chamber) Top		2	MEI021	2	ME2021	
Front & Rear Cover (Bus Bar Chamber) Bottom		2	MEI022	2	ME2022	
Rear Door		1	MEI023	N/R		

DRAWOUT TYPE				BOLTED							
DRAWOUT TYPE				FIXED TYPE				DRAWOUT TYPE			
SINGLE FRONT		DOUBLE FRONT		SINGLE FRONT		DOUBLE FRONT		SINGLE FRONT		DOUBLE FRONT	
Qty.	Order No.	Qty.	Order No.	Qty.	Order No.	Qty.	Order No.	Qty.	Order No.	Qty.	Order No.
1	ME3001	1	ME4001	1	ME5001	1	ME6001	1	ME7001	1	ME8001
2	ME3002	4	ME4002	2	ME5002	4	ME6002	2	ME7002	4	ME8002
1	ME3003	3	ME4003	1	ME5003	3	ME6003	1	ME7003	3	ME8003
4	ME3004	4	ME4004	4	ME5004	4	ME6004	4	ME7004	4	ME8004
2	ME3005	2	ME4005	2	ME5005	2	ME6005	2	ME7005	2	ME8005
2	ME3006	2	ME4006	2	ME5006	2	ME6006	2	ME7006	2	ME8006
2	ME3007	2	ME4007	2	ME5007	2	ME6007	2	ME7007	2	ME8007
2	ME3008	2	ME4008	2	ME5008	2	ME6008	2	ME7008	2	ME8008
1	ME3009	2	ME4009	1	ME5009	2	ME6009	1	ME7009	2	ME8009
1	ME3010	2	ME4010	1	ME5010	2	ME6010	1	ME7010	2	ME8010
2	ME3011	2	ME4011	2	ME5011	2	ME6011	2	ME7011	2	ME8011
6	ME3012	6	ME4012	6	ME5012	6	ME6012	6	ME7012	6	ME8012
4	ME3013	4	ME4013	N / R							
2	ME3014	4	ME4014	N / R							
4	ME3015	4	ME4015	N / R							
6	ME3016	12	ME4016	6	ME5013	12	ME6013	6	ME7013	12	ME8013
2	ME3017	2	ME4017	1	ME5014	1	ME6014	1	ME7014	1	ME8014
4	ME3018	4	ME4018	4	ME5015	4	ME6015	4	ME7015	4	ME8015
2	ME3019	2	ME4019	2	ME5016	2	ME6016	2	ME7016	2	ME8016
2	ME3020	2	ME4020	2	ME5017	2	ME6017	2	ME7017	2	ME8017
2	ME3021	2	ME4021	2	ME5018	2	ME6018	2	ME7018	2	ME8018
2	ME3022	2	ME4022	2	ME5019	2	ME6019	2	ME7019	2	ME8019
1	ME3023	N/R		1	ME5020	N/R		1	ME7020	N/R	

Contd....

MCC ENCLOSURE PARTS DETAIL

MCC PARTS DETAIL		WELDED			
COMPARTMENT	DESCRIPTION	FIXED TYPE			
		SINGLE FRONT		DOUBLE FRONT	
		Qty.	Order No.	Qty.	Order No.
 <p>Covers</p>	Cable Alley Rear Door	1	MEI024	N/R	
	Cable Alley Front Door	1	MEI025	2	ME2023
	Busbar Chamber Door	1	MEI026	1	ME2024
	Partition Tray Bottom	1	MEI027	2	ME2025
	Partition Tray Top	1	MEI028	2	ME2026
	Main Busbar Cover Plate	1	MEI029	1	ME2027
	Top Sheet	1	MEI030	2	ME2028
	Aux. Bus Bar Shroud For HBB	1	MEI031	2	ME2029
	Partition Tray	APR	MEI032	APR	ME2030
	 <p>Doors</p>	Front Door 200 mm (H)	1	MEI033	2
Front Door 225 mm (H)		1	MEI034	2	ME2032
Front Door 300 mm (H)		1	MEI035	2	ME2033
Front Door 450 mm (H)		1	MEI036	2	ME2034
Front Door 600 mm (H)		1	MEI037	2	ME2035
Front Door 750 mm (H)		1	MEI038	2	ME2036
Front Door 900 mm (H)		1	MEI039	2	ME2037
Front Door 1200 mm (H)		1	MEI040	2	ME2038
Front Door 1500 mm (H)		1	MEI041	2	ME2039
Front Door 1800 mm (H)		1	MEI042	2	ME2040
 <p>Feeder Compartment</p>	Feeder Fixing Plate LHS & RHS 200 mm	1	MEI043	2	ME2041
	Mounting Plate 200 mm				
	Feeder Fixing Plate LHS & RHS 225 mm	1	MEI044	2	ME2042
	Mounting Plate 225 mm				
	Feeder Fixing Plate LHS & RHS 300 mm	1	MEI045	2	ME2043
	Mounting Plate 300 mm				
	Feeder Fixing Plate LHS & RHS 450 mm	1	MEI046	2	ME2044
	Mounting Plate 450 mm				
	Feeder Fixing Plate LHS & RHS 600 mm	1	MEI047	2	ME2045
	Mounting Plate 600 mm				
Feeder Fixing Plate LHS & RHS 900 mm	1	MEI048	2	ME2046	
Mounting Plate 900 mm					

DRAWOUT TYPE				BOLTED							
DRAWOUT TYPE				FIXED TYPE				DRAWOUT TYPE			
SINGLE FRONT		DOUBLE FRONT		SINGLE FRONT		DOUBLE FRONT		SINGLE FRONT		DOUBLE FRONT	
Qty.	Order No.	Qty.	Order No.	Qty.	Order No.	Qty.	Order No.	Qty.	Order No.	Qty.	Order No.
1	ME3024	N/R		1	ME5021	N/R		1	ME7021	N/R	
1	ME3025	2	ME4023	1	ME5022	2	ME6020	1	ME7022	2	ME8020
N/R		N/R		1	ME5023	1	ME6021	N/R		N/R	
1	ME3026	2	ME4024	1	ME5024	2	ME6022	1	ME7023	2	ME8021
1	ME3027	2	ME4025	N/R							
1	ME3028	1	ME4026	N/R							
1	ME3029	2	ME4027	1	ME5025	2	ME6023	1	ME7024	2	ME8022
1	ME3030	2	ME4028	1	ME5026	2	ME6024	1	ME7025	2	ME8023
APR	ME3031	APR	ME4029	APR	ME5027	APR	ME6025	APR	ME7026	APR	ME8024
1	ME3032	2	ME4030	1	ME5028	2	ME6026	1	ME7027	2	ME8025
1	ME3033	2	ME4031	1	ME5029	2	ME6027	1	ME7028	2	ME8026
1	ME3034	2	ME4032	1	ME5030	2	ME6028	1	ME7029	2	ME8027
1	ME3035	2	ME4033	1	ME5031	2	ME6029	1	ME7030	2	ME8028
1	ME3036	2	ME4034	1	ME5032	2	ME6030	1	ME7031	2	ME8029
1	ME3037	2	ME4035	1	ME5033	2	ME6031	1	ME7032	2	ME8030
1	ME3038	2	ME4036	1	ME5034	2	ME6032	1	ME7033	2	ME8031
1	ME3039	2	ME4037	1	ME5035	2	ME6033	1	ME7034	2	ME8032
1	ME3040	2	ME4038	1	ME5036	2	ME6034	1	ME7035	2	ME8033
1	ME3041	2	ME4039	1	ME5037	2	ME6035	1	ME7036	2	ME8034
NR		NR		1	ME5038	2	ME6036	NR		NR	
NR		NR		1	ME5039	2	ME6037	NR		NR	
NR		NR		1	ME5040	2	ME6038	NR		NR	
NR		NR		1	ME5041	2	ME6039	NR		NR	
NR		NR		1	ME5042	2	ME6040	NR		NR	
NR		NR		1	ME5043	2	ME6041	NR		NR	

Contd....

MCC ENCLOSURE PARTS DETAIL

MCC PARTS DETAIL		WELDED			
COMPARTMENT	DESCRIPTION	FIXED TYPE			
		SINGLE FRONT		DOUBLE FRONT	
		Qty.	Order No.	Qty.	Order No.
Feeder Compartment 	Feeder Fixing Plate LHS & RHS 1200 mm	1	MEI049	2	ME2047
	Mounting Plate 1200 mm				
	Feeder Fixing Plate LHS & RHS 1500 mm	1	MEI050	2	ME2048
	Mounting Plate 1500 mm				
	Feeder Fixing Plate LHS & RHS 1800 mm	1	MEI051	2	ME2049
	Mounting Plate 1800 mm				
Channel 	Shroud Fixing Channel		NR		NR
	O/G Male Contact Fixing Channel		NR		NR
	VBB Shroud Fixing Channel		NR		NR
	LHS/RHS Vertical Channel		NR		NR
	VBB Shroud Cover		NR		NR
	VBB Shroud (For All Compartments)		NR		NR
	Main Supporting Bottom Channel (Width)		NR		NR
	Bottom Tie Channel (Width)		NR		NR
	D/F Side Section		NR		NR
	L for LHS / RHS		NR		NR
Trolley 	Trolley Size 300 mm VBB Shroud 300 mm		NR		NR
	Trolley Size 450 mm VBB Shroud 450 mm		NR		NR
	Trolley Size 600 mm VBB Shroud 600 mm		NR		NR
	Trolley Size 750 mm VBB Shroud 750 mm		NR		NR
	Trolley Size 900 mm VBB Shroud 900 mm		NR		NR

DRAWOUT TYPE				BOLTED							
DRAWOUT TYPE				FIXED TYPE				DRAWOUT TYPE			
SINGLE FRONT		DOUBLE FRONT		SINGLE FRONT		DOUBLE FRONT		SINGLE FRONT		DOUBLE FRONT	
Qty.	Order No.	Qty.	Order No.	Qty.	Order No.	Qty.	Order No.	Qty.	Order No.	Qty.	Order No.
NR		NR		1	ME5044	2	ME6042	NR		NR	
NR		NR		1	ME5045	2	ME6043	NR		NR	
NR		NR		1	ME5046	2	ME6044	NR		NR	
1	ME3042	1	ME4040	NR		NR		1	ME7037	1	ME8035
2	ME3043	2	ME4041	NR		NR		2	ME7038	2	ME8036
6	ME3044	16	ME4042	NR		NR		6	ME7039	16	ME8037
2	ME3045	4	ME4043	NR		NR		2	ME7040	4	ME8038
1	ME3046	2	ME4044	NR		NR		1	ME7041	2	ME8039
1	ME3047	1	ME4045	NR		NR		1	ME7042	1	ME8040
NR		2	ME4046	NR		NR		NR		2	ME8041
NR		1	ME4047	NR		NR		NR		1	ME8042
NR		2	ME4048	NR		NR		NR		2	ME8043
NR		2	ME4049	NR		NR		NR		2	ME8044
1	ME3048	2	ME4050	NR		NR		1	ME7043	2	ME8045
1	ME3049	2	ME4051	NR		NR		1	ME7044	2	ME8046
1	ME3050	2	ME4052	NR		NR		1	ME7045	2	ME8047
1	ME3051	2	ME4053	NR		NR		1	ME7046	2	ME8048
1	ME3052	2	ME4054	NR		NR		1	ME7047	2	ME8049

Bus Bars

Our bus bar design is calculated to withstand the short time current and the bus bar sizing also is done accordingly. Bus bar can be either aluminum E91E or electrolytic grade copper as per customer requirement. Bus bars are fully shrouded and the draw out fixed contacts is shrouded by automatic shutters. Once the trolley is drawn out, the bus bar will be fully shrouded and thus avoid any accidental contact with live bus bar. The horizontal bus bar chamber height is 300mm which is fully isolated from compartment. We use sturdy silver plated draw out contacts.

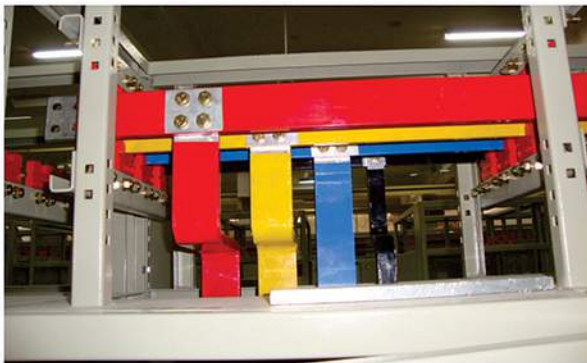

Horizontal Bus bar

Main horizontal bus bars are running through out length of the panel with the provision to extend on either side, Busbar can be E91E grade of aluminum or HDHC (height density, high conductivity) copper according to requirement of customer.



- Our bus bars are tested for short circuit test of 50 ka for 1 second as per IS: 8623(part1)- 1993/IEC pub 439-1(1985)
- Our busbar are also tested for temperature rise as per IS: 8623(part1)-1993/IEC pub 439-1(1985)

ACB Connection Bus



Vertical Bus Bar Connections

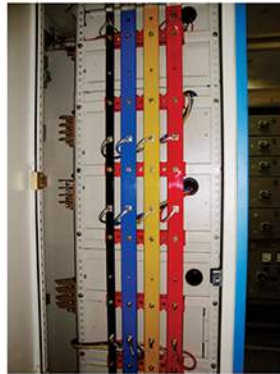

Minimum clearance in Air in mm :

- Between Phases - 25.4mm
 - Between live parts & ground – 19.0mm
 - Minimum Size of bus bar: 50 x 12 mm for aluminum & 50 x 10 mm for copper.
- We are using high tensile 10.8 grade fasteners for busbar joints and fixing the busbar to avoid any shearing tendency of fasteners during short circuit.

Bus bars with Acrylic protection



TPN Insulator with every 225/300 mm gap



Bus Bar Support



We are using SMC busbar support which has good mechanical strength and tracking withstand capacity

We are using SMC 20 & SMC 25 grade material supports (tested for mechanical strength in ERDA/CPRI) depending upon fault level.

SMC 25 grade stronger to withstand fault current and is costlier by 20% than SMC – 20. We are using finger type busbar support for each phase independently.

For vertical droppers we are using TPN bus bar support.

One Way Finger Type Insulator



Two Way Finger Type Insulator



HORIZONTAL BUSBAR SELECTION

RATING	HORIZONTAL BUSBAR		LENGTH OF HBB PER VERTICAL AS INCOMER (mtr)	SMC FINGER TYPE INSULATOR FOR BUSBAR	NO. OF INSULATOR PER VERTICAL	STANDARD HIGH TENSILE FASTNER	NO. OF FASTNERS PER VERTICAL	ORDER NO. PER SET
	SIZE HXD (mm)	RUNS						
4000	150 X 10	4	15.4	10 mm Four Way	24	M 12 X 100	16	MEBB01
3200	100 X 10	4	15.4	10 mm Four Way	24	M 12 X 100	16	MEBB02
2500	100 X 12	3	12.1	12 mm Three Way	24	M 12 X 80	16	MEBB03
2000	100 X 12	2	9.0	12 mm Two Way	24	M 12 X 50	16	MEBB04
1600	100 X 10	2	9.0	10 mm Two Way	24	M 12 X 50	16	MEBB05
1250	75 X 12	2	9.0	12 mm Two Way	24	M 12 X 50	16	MEBB06
1000	75 X 10	2	9.0	10 mm Two Way	24	M 10 X 50	16	MEBB07
800	100 X 10	1	4.0	10 mm One Way	24	M 10 X 30	16	MEBB08

* Other Electrical Accessories like terminal, wires, lugs, markers, copper connector, earthing, hardware also available as per your requirement.

Bus Bars Arrangements



DRAWOUT MCC

Drawout Components:

INTERNAL SEGREGATION:

Trolleys – The trolleys are designed with great precision to avoid any mismatch of draw out contacts, power as well as control SIC contacts. The trolleys are having three distinct positions, isolated, test and service. Standard trolley size – 300mm, 375mm, 450mm, 600mm, 750mm and 900mm. Our Trolleys are riveted type Alu Zinc Material.

Drawout Contacts:

Silver plated copper
(tested for 50kA as per IS 8623/ IEC 439).

Power & Control Contacts:

Silver plated copper
(tested for 50kA as per IS 8623/ IEC 439).

Earthing:

Provided by scrapping earth assembly.

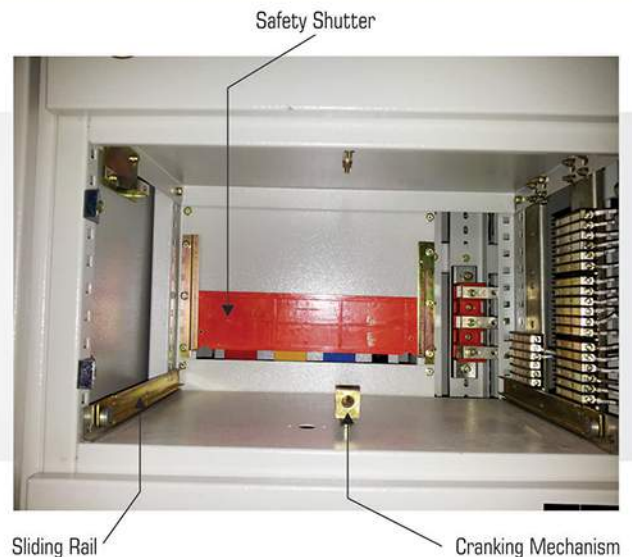

Miscellaneous Drawout Components:

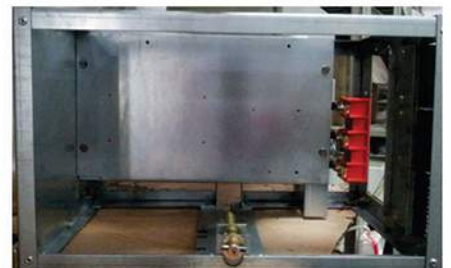

TYPE TEST CERTIFICATE

Short Circuit Withstand: (1600A) 50KA for 1sec.

Temperature Rise- 1600A

ELECTRICAL RESEARCH AND DEVELOPMENT ASSOCIATION (Approved by the National Accreditation Board for Testing and Calibration Laboratories, Govt. of India) ERDA Road, Makarpura Industrial Estate, Vadodra-390 010, India. EPABX : +91 (022) 2842942, 2842964, 2842977, 2843128 / 29 / 30 / 31 / 33. Fax : +91 (022) 2838392 E-mail : erda@erda.org Web : http://www.erda.org		ERDA
TEST REPORT Sheet: 1 of 5		
NAME & ADDRESS OF CUSTOMER PYROTECH ELECTRONICS PVT. LTD. (UNIT-II) E-329, Road No.12, M.I.A., Udaipur - 313 003, INDIA	REPORT NO: PLV/10/SC/1882 DATE: 26.02.2010 CUSTOMER REF. NO.: Nil DATE: 25.01.2010 DATE OF SAMPLE RECEIPT: 27.01.2010 DATE OF TESTING: 29.01.2010 to 30.01.2010	
SAMPLE DESCRIPTION MOTOR CONTROL CENTRE (MCC) PANEL Rated current (Ie): 1600 A Rated operational voltage (Ue): 415 V No. of Phases : Three + Neutral Rated frequency: 50 Hz, Rated insulation voltage (Ui): 1000 V Rated short time withstand current & its duration: - 50 kArms for 1 Sec. with an initial peak of 105 kA between adjacent phase & neutral. - 50 kArms for 1 Sec. with an initial peak of 105 kA between adjacent phase & neutral. Further details as per sheet No. 3 of 5	SAMPLE IDENTIFICATION ERDA ID NO: LSCLWO 00710003/01 DRAWING NO: 027560 REV.00 SHEET 1 OF 5 REV.00 027560 REV.00 SHEET 2 OF 5 REV.00 027560 REV.00 SHEET 3 OF 5 REV.00 027560 REV.00 SHEET 4 OF 5 REV.00 027560 REV.00 SHEET 5 OF 5 REV.00	
TEST DETAILS Verification of the short-circuit withstand strength (Cl. No. B.2.3)	TEST SPECIFICATIONS As per customer's requirement & test procedure followed as per IS 8623 (Part 1):1993 IEC Pub 439-1(1985)	
ENCLOSURES: Number of oscillograms : Two Number of photograph : One Number of test circuit diagrams : Two Number of drawings : Five		
TEST WITNESSED BY: Mr. Arjun Lal Bansival		
REMARKS: The sample conforms to the requirement of verification of the short-circuit withstand strength as specified by customer.		
PREPARED BY [Signature]	CHECKED BY [Signature]	APPROVED BY [Signature]
<small>NOTE: 1. This report relates only to the particular sample received for testing in good condition at ERDA. 2. This report cannot be reproduced in part under any circumstances. 3. Publication of this report requires prior permission in writing from Director, ERDA. 4. Only test used for by customer have been carried out.</small>		

ELECTRICAL RESEARCH AND DEVELOPMENT ASSOCIATION (Approved by the National Accreditation Board for Testing and Calibration Laboratories, Govt. of India) ERDA Road, Makarpura Industrial Estate, Vadodra-390 010, India. EPABX : +91 (022) 2842942, 2842964, 2842977, 2843128 / 29 / 30 / 31 / 33. Fax : +91 (022) 2838392 E-mail : erda@erda.org Web : http://www.erda.org		ERDA
TEST REPORT Sheet: 1 of 3		
NAME & ADDRESS OF THE CUSTOMER PYROTECH ELECTRONICS PVT. LTD. (UNIT - II) E- 329, ROAD NO. 12, M.I.A., UDAIPUR - 313 003, INDIA.	TEST REPORT NO.: LSWG/2119 DATE : 10/12/2009 CUSTOMER REF. NO.: Nil DATE : 25/11/2009 DATE OF SAMPLE RECEIPT: 24/11/2009 DATE OF TESTING: 28/11/2009	
SAMPLE DESCRIPTION 1000 A MCC PANEL Rated voltage : 415 V Rated current : 1000 A Rated frequency : 50 Hz No. of phases : 3 + N Quantity (Tested) : 1 No.	SAMPLE IDENTIFICATION ERDA Sample code no. : LSWG00077716/01 Drawing No.: i) 027464 (Rev.0) (sheet 1 of 2) ii) 027464 (Rev.0) (sheet 2 of 2) Manufacturer's name : M/s. Pyrotech Electronics Pvt. Ltd.	
TEST DETAILS 1.0 Verification of temperature rise limits (Cl. no. B.2.1) 2.0 mill volt drop measurement	TEST SPECIFICATION As per customer requirement & test procedure followed as per IS : 8623 (Part 1) : 1993 IEC Pub 439 - 1 (1985)	
ENCLOSURES : Drawing No. : i) 027464 (Rev.0) (sheet 1 of 2) ii) 027464 (Rev.0) (sheet 2 of 2)		
NOTE : As per customer's requirement temperature rise test was carried out on Horizontal busbars only.		
TEST WITNESSED BY : Mr. Arjun Bansival of M/s. Pyrotech Electronics Pvt. Ltd.		
REMARKS : Sample conforms to the requirements of the customer for the tests carried out.		
PREPARED BY [Signature]	CHECKED BY [Signature]	APPROVED BY [Signature]
<small>NOTE: 1. This report relates only to the particular sample tested in good condition. 2. This report can not be reproduced in part under any circumstances. 3. Publication of this report requires prior permission in writing from Director, ERDA. 4. Only the tests asked for by the customer have been carried out.</small>		

IP TEST (IP: 53/54)

IP TEST (IP: 55)

ELECTRICAL RESEARCH AND DEVELOPMENT ASSOCIATION (Approved by the National Accreditation Board for Testing and Calibration Laboratories, Govt. of India) ERDA Road, Makarpura Industrial Estate, Vadodra-390 010, India. EPABX : +91 (022) 2842942, 2842964, 2842977, 2843128 / 29 / 30 / 31 / 33. Fax : +91 (022) 2838392 E-mail : erda@erda.org Web : http://www.erda.org		ERDA
TEST REPORT Sheet: 1 of 3		
NAME AND ADDRESS OF CUSTOMER PYROTECH ELECTRONICS PVT. LTD. (UNIT-II) E-329, ROAD NO.12, M.I.A., UDAIPUR - 313003, INDIA.	TEST REPORT NO: LIPS/473 DATE : 17/05/2010 CUSTOMER REF. NO.: PEPLUI-2/QA/01 DATE : 29/04/2010 DATE OF SAMPLE RECEIPT: 29/04/2010 DATE OF TESTING: 29/04/2010 to 30/04/2010	
SAMPLE DESCRIPTION MCC PANEL Containing : SFU, Terminal block	SAMPLE IDENTIFICATION ERDA sample code no.: LSWG00081141/01 Drg. No.: 028885 (Rev. 0) (Sheet 1 of 1) Sr. No.: Nil	
TEST DETAILS 1.0 IP 53 tests	TEST SPECIFICATION Cl. No. 7.1.11 of IS/IEC : 60947-1-2004	
Enclosures : i) Drg. No.: 028885 (Rev. 0) (Sheet 1 of 1) ii) Photograph No. : i) 81141/01/1 ii) 81141/01/2		
Test Witnessed by: Mr. Arjunlal Bansival of M/s. Pyrotech Electronics Pvt. Ltd., Udaipur.		
REMARKS: Sample conforms to the requirement of IP 53 tests as per the standard.		
PREPARED BY [Signature]	CHECKED BY [Signature]	APPROVED BY [Signature]
<small>NOTE: 1. This report relates only to the particular sample received for testing in good condition at ERDA. 2. This report cannot be reproduced in part under any circumstances. 3. Publication of this report requires prior permission in writing from Director, ERDA. 4. Only the tests asked for by the customer have been carried out. 5. In case of any dispute, arbitrators will be the exclusive jurisdiction & shall be construed as where the cause has arisen. CAUTION: ERDA is not responsible for the authenticity of photocopied or reproduced test reports. ERDA provides support to customers for verification of the authenticity of test reports issued by ERDA.</small>		

ELECTRICAL RESEARCH AND DEVELOPMENT ASSOCIATION (Approved by the National Accreditation Board for Testing and Calibration Laboratories, Govt. of India) ERDA Road, Makarpura Industrial Estate, Vadodra-390 010, India. EPABX : +91 (022) 2842942, 2842964, 2842977, 2843128 / 29 / 30 / 31 / 33. Fax : +91 (022) 2838392 E-mail : erda@erda.org Web : http://www.erda.org		ERDA
TEST REPORT Sheet: 1 of 3		
NAME AND ADDRESS OF CUSTOMER PYROTECH ELECTRONICS PVT. LTD. (UNIT-IV) A-193, MEWAR INDUSTRIAL AREA, MADAI, UDAIPUR 313003 (RAJ.), INDIA.	TEST REPORT NO: RP-1314-003880 DATE : 27/06/2013 CUSTOMER REF. NO.: Nil DATE : 21/06/2013 & 28/06/2013 DATE OF SAMPLE RECEIPT: 21/06/2013 DATE OF TESTING: 22/06/2013 to 24/06/2013	
SAMPLE DESCRIPTION MCC (DRAW OUT TYPE) Containing: Terminal, NCBS, MCCB, Terminal block	SAMPLE IDENTIFICATION ERDA sample code No. : ERDA-00010459 Drg. No.: 02-01-06-1631 (Rev.0) (Sheet 1 of 1) (Total 1 sheet) Sr.No.: Nil	
TEST DETAILS 1.0 IP 55 tests	TEST SPECIFICATION Cl. No. 7.1.11 of IS/IEC 60947-1:2004	
Enclosures : i) Photograph No. : a) ERDA-00010459/1 b) ERDA-00010459/2 ii) Drg. No. : 02-01-06-1631 (Rev.0) (Sheet 1 of 1) (Total 1 sheet)		
Test Witnessed By: Mr. Arjunlal Bansival of M/s. Pyrotech Electronics Pvt. Ltd., Udaipur.		
REMARKS: Sample conforms to the requirement of IP 55 tests as per the standard.		
PREPARED BY [Signature]	CHECKED BY [Signature]	APPROVED BY [Signature]
<small>NOTE: 1. This report relates only to the particular sample received for testing in good condition at ERDA. 2. This report cannot be reproduced in part under any circumstances. 3. Publication of this report requires prior permission in writing from Director, ERDA. 4. Only the tests asked for by the customer have been carried out. 5. In case of any dispute, arbitrators will be the exclusive jurisdiction & shall be construed as where the cause has arisen. CAUTION: ERDA is not responsible for the authenticity of photocopied or reproduced test reports. ERDA provides support to customers for verification of the authenticity of test reports issued by ERDA.</small>		

• Temperature Rise - 4000 A • Short Curcuit Test (4000 A) - 50kA/Sec

SHEET PUNCHING



CNC Turret Punch Press (2013)
 (Make-Murtec, Japan)
 Punching Capacity 20 Tons
 Punching Accuracy 0.1 mm
 Working Length 1250 X 2500 mm
 Maximum Sheet Thickness 3.2 mm

SHEET PUNCHING



CNC Turret Punch Press (2013)
 (Make-Amada, Japan)
 Punching Capacity 20 Tons
 Punching Accuracy 0.02 mm
 Working Length 1250 X 2500 mm
 Maximum Sheet Thickness 3.2 mm

SHEET PUNCHING



CNC LINE S4 (2013)
 (Make-Salvagni, Italy)
 Punching Capacity 20 Tons
 Punching Accuracy 0.1 mm
 Working Length 1250 X 2500 mm
 Maximum Sheet Thickness 3.2 mm

SHEET BENDING



CNC LINE P4 (2013)
 (Make-Salvagni, Italy)
 Bending Accuracy 0.02 mm
 Working Length 1250 X 2500 mm
 Maximum Sheet Thickness 2.0 mm

SHEET SHEARING



NC Hydraulic Shear Machine (2000)
 Capacity 4 mm X 3000 mm
 Work Length 4 x 1000 mm
 Accuracy up to 0.5 mm
 Tolerance 0.5 mm

SHEET BENDING



Power Folder Futura Plus-25
 (Make- CIDAN, Sweden)
 Folding Length 2600 mm
 Capacity at 400 N/sq. mm 3.5 mm
 Opening Height Clamping Beam 195 mm
 Motor Clamping Beam 2.2 kv
 Motor Folding Beam 1.5+1.5 kv
 Weight ca.4295 kg

SHEET BENDING



Make- Amada, Japan
Capacity - 80 Ton
Accuracy - 0.1 mm
Working Length - 2600 mm

SURFACE TREATMENT



HOT 7 Tank Surface Treatment
Capacity 7000 L Provides complete surface Treatment which involves processes like Degreasing, Rinsing, Derusting, Cleaning & Rinsing, Cleaning, Activation, Phosphating, Rinsing, Passivation.

SPRAY PRETREATMENT EQUIPMENT



Conveyorized Surface Treatment
(Make- Huali, China)
Complete surface Treatment which involves processes like Predegreasing, Degreasing, Rinsing 1, DI Water Rinsing 1, NT 1, DI Water Rinsing 2, DI Water Rinsing 3, DI Water Spray.

POWDER COATING LINE



Powder Coating Booth, India
Fully Automatic Conveyorized.
Powder Coating Plant suitable for epoxy base Polyester Coating.

POWDER AUTOMATIC SPRAYING SYSTEM



Steel Sheet Surface Coating Automatic
(Make- Huali, China)
Control Production Line
Maximum Size of work piece :
L 2400 x W 1000 x H 1500
Powder Coating : Electric Static Spray
Conveyor Speed : 3.5m/min (0.5~4.5)m/min adjustable.

GASKET MACHINE



Gasketing Machine
(Make- Sonderhoff, Germany)
Working Length 30X

Major clients who believes in us...



An ISO 9001, EMS 14001, OHSAS 18001 Company

PYROTECH ELECTRONICS PVT. LTD. - UNIT IV

A-193, Mewar Industrial Area, Madri, Udaipur-313003, Rajasthan, India

Pyrotech Electronics Pvt. Ltd was established in 1976 at Udaipur, Rajasthan having more than 35 years experience in Turnkey control room interiors, Mosaic Panels & Desks, Control Panels & Desks, other Industrial Panels, Junction Boxes & Racks and more than 10 years experience of Supply, Installation & Commissioning in video wall market. We have our reach to the Power, Energy G/D/T, Oil & Gas, Metal, Transport, Defense & Cement industries etc..

E-329, Road No. 12,
Mewar Industrial Area, Udaipur - 313 003,
Ph: +91-294-2492122/31/34, Fax: 2492130,
E-mail: pyrotech@pyrotechindia.com,
marketing@pyrotechindia.com

C-140, Sector 63,
Noida-201301 (Uttar Pradesh),
Mobile : +91-88004 88792,
E-mail : pmppl@pyrotechindia.com,
electricals@pyrotechindia.com

Regional Marketing Offices :-

- Ahmedabad
- Bhopal
- Kolkata
- Baroda
- Delhi
- Mumbai
- Bangalore
- Hyderabad
- Chennai